

## Multiple-joint hinge

concealed, opening angle 180°

### SPECIFICATION

Aluminum **AL**  
anodized, natural color **EL**

Hinge pins / washers  
Stainless Steel 304

Friction bearing  
Plastic

- self lubricated
- temperature resistant -40 °C to 90 °C

### INFORMATION

The multiple-joint hinge GN 7247 is installed on the inside of doors, flaps and hatches to save space and ensure protection against vandalism. The hinge has a maximum opening angle of 180°, which provides optimal accessibility and avoids the blocking of escape routes by open doors, for example.

Use of this hinge type leaves housing exteriors free of attachments that do not match the design or that should be avoided entirely in the interests of fast and easy cleaning.

Multiple-joint hinges are generally used in pairs. For higher loads, e.g. from large doors, these can be supplemented with additional hinges. Four reinforced washers are supplied, which can be used with fastening screws of thread size M6.

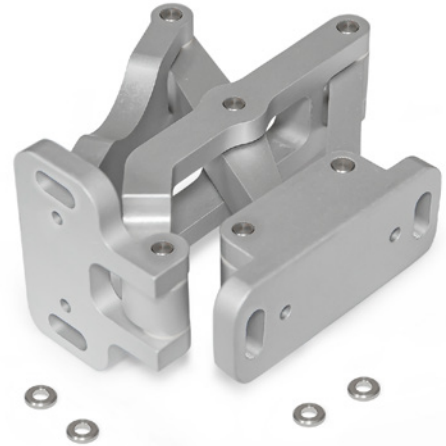

### TECHNICAL INFORMATION

- Stainless Steel characteristics (see page A26)

### ON REQUEST

- other finishes / colors
- other fastening flanges
- other opening angles
- other max. wall thicknesses
- other lifting motion

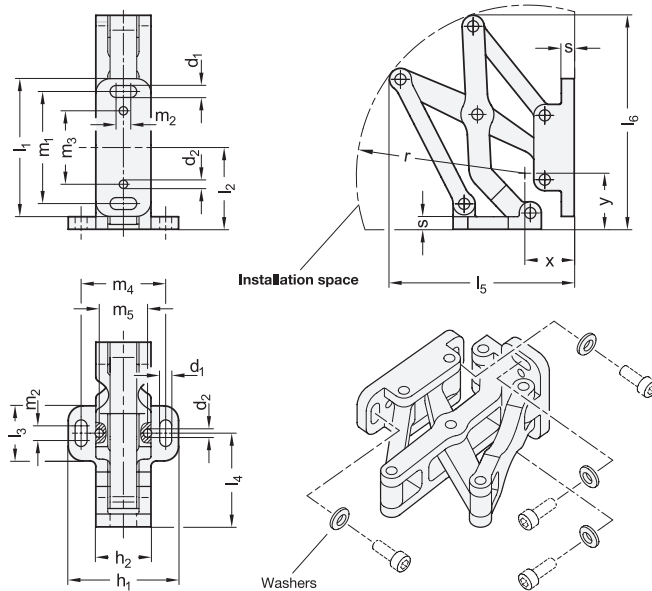

### GN 7247

Description	l1	d1	d2	h1	h2	l2	l3	l4	l5	l6	l7	l8	l9	l10	m1	m2	m3	m4	m5	r	s	x	y	
GN 7247-AL-75-EL	75	6.5	4	60	30	44.5	30	51	100.5	116.5	74.3	29.5	74	27	61	8	40	46	28	93	7	26	29	320

**Installation position - pivot characteristics**

The multiple-joint hinges can be installed to the housing with the slots on the fastening flanges either parallel or perpendicular to the hinge axis. This results in the two pivot characteristics depicted.

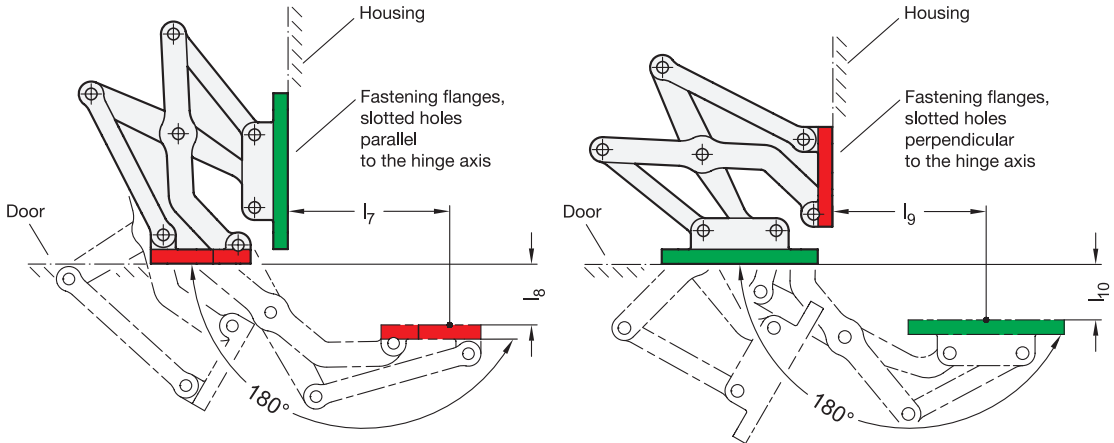

**Examples of use**

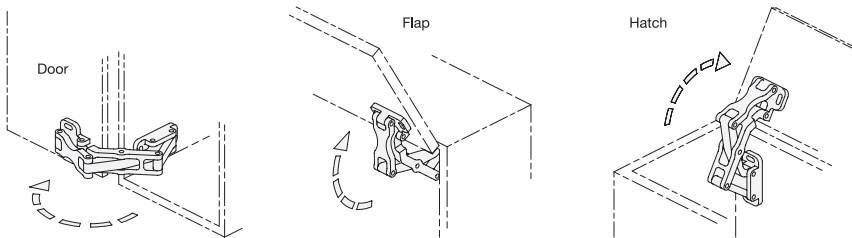

**Adjustment and fastening options**

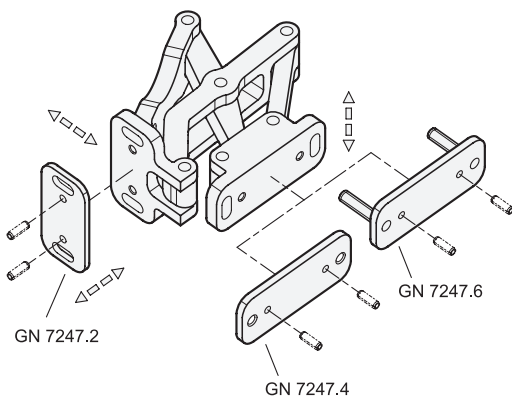

The multiple-joint hinges can be adjusted in three planes during installation. For example, this allows adjustment for tolerances or establishing of required compressive forces for seals.

Two planes can be adjusted via parallel or perpendicular slots in the fastening flanges. In the third plane, position corrections can be made using the Stainless Steel-Spacer plates GN 7247.2 (see page ), Stainless Steel-Plates with tapped holes GN 7247.4 (see page ) as well as Stainless Steel-Plates with threaded studs GN 7247.6 (see page ). The latter can be welded on or inserted through the wall from the outside and fastened in place. The holes d2 receive tensioning or positioning pins, making it easy to position the hinge. This also prevents unintended turning or slipping under load. The pins cannot be removed for subsequent adjustment.



**Design variants**

Doors, flaps and hatches can be inset, flush or mitered. The maximum wall thicknesses and bend sizes for sheet metal constructions given below arise from the respective installation type.

1. Fastening flange mounted to the housing with slots parallel to the hinge axis:

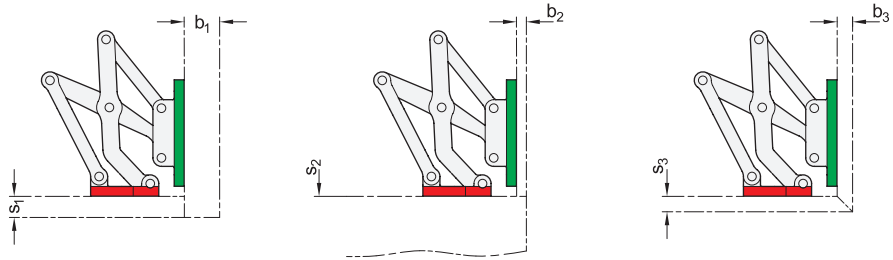

l1	s1 max.	b1	s2	b2 max.	s3 max.	b3 max.
75	15	24	1 ... ∞	8	11	11

2. Fastening flange mounted to the housing with slots perpendicular to the hinge axis:

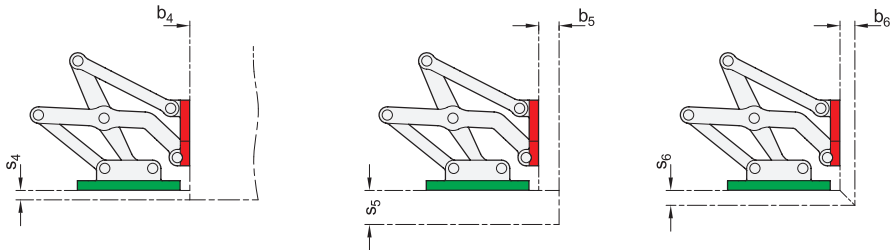

l1	s4 max.	b4	s5	b5 max.	s6 max.	b6 max.
75	8	1 ... ∞	24	15	11	11

The design variants shown represent standard installation conditions. If the installation position of the hinge is changed or one of the two wall thickness dimensions is lower than s or b, the maximum achievable dimensions change independently of each other. This makes it possible in some cases to work with larger wall thickness dimensions than those specified with the same hinge size. A simple design check via CAD or a test setup is therefore recommended.



Example of an assembly

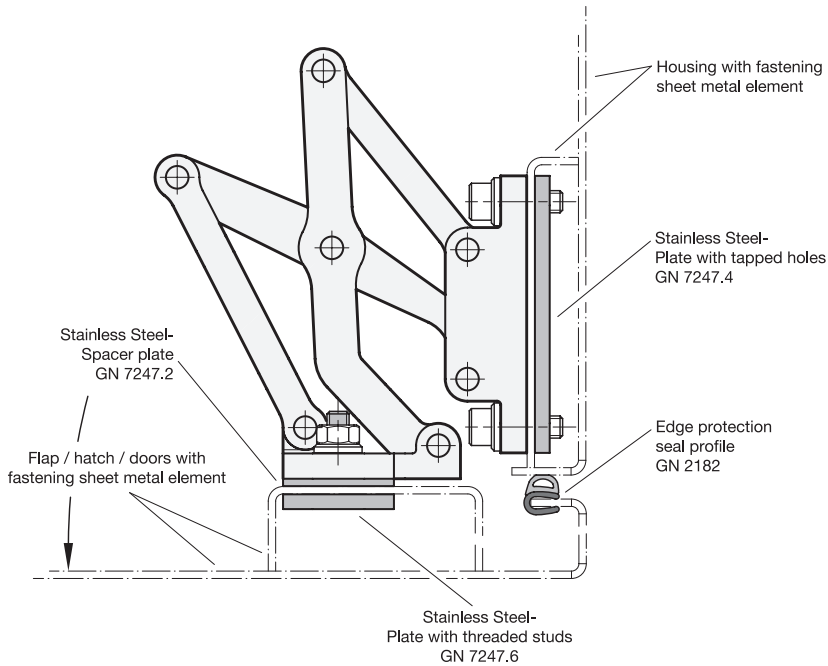

Load capacity

The maximum load of the multiple-joint hinge specified below applies to the standard use cases and serves for orientation in the case of deviating applications. The resulting forces lead to slight elastic deformation, which can be compensated for by means of the adjustment options, if necessary.

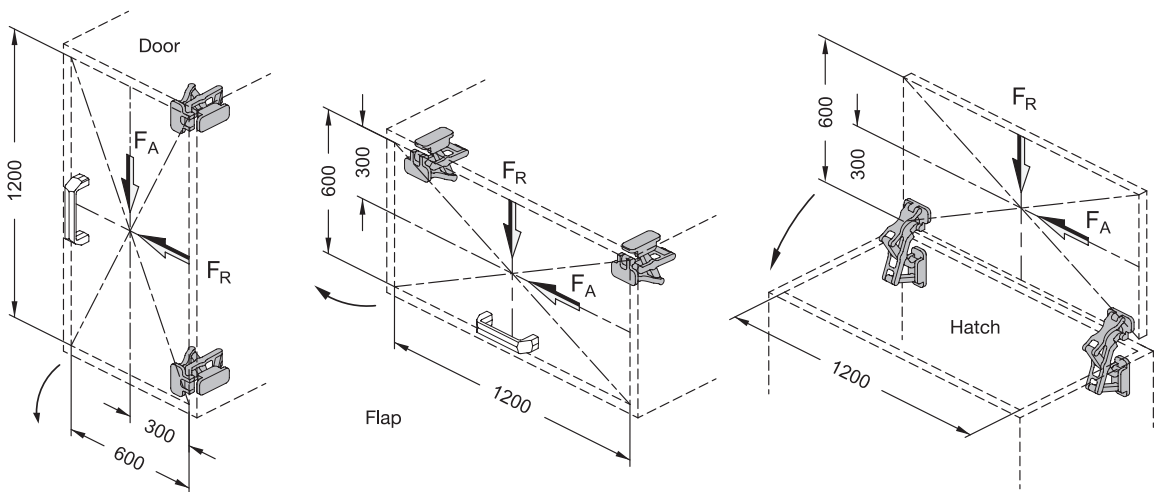

Load capacity per hinge pair in N	FA (axial)	FR (radial)
li		
75	650	750

